

Bear UPS

High Power Temperature Compensated

One of the main issues with electrifying oil/gas separator controls is how to shut down safely when your power fails.

The Bear UPS, which is a 25 amp -40°C Div2 rated backup power supply, gives time for equipment to shut down properly for up to one hour when the main power fails. The ability to supply 25 amps continuously allows multiple actuators to run at the same time without blowing a fuse. Combined with the Bear Fail Safe Controller, it will facilitate your fail safe zero emission electric separator designs

Features:

- Class I Div2 Certified from -40°C to 50°C
- Low quiescent current for solar powered operation
- Temperature compensated charging voltage
- Works with 12 or 24VDC power supplies
- 25 Amps Maximum continuous current rating

Typical Applications

- Separator Control Systems



General Magnetic

www.generalmagnetic.ca

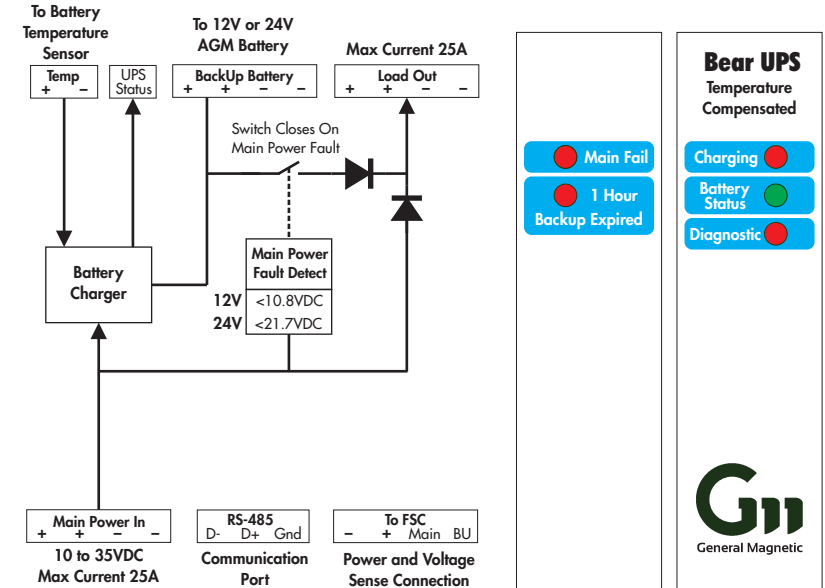

Function Diagram

Principles of Operation

As the temperature drops an AGM battery needs to have a higher voltage to properly charge. A UPS fixed charge voltage will either be too high (warmer environments) or too low (colder environments). This will result in over- or under-charging the battery. Inaccurate charging, particularly over-charging, which results in excessive heat buildup and chemical degradation of the battery. These, in turn, can shorten battery life. The Bear UPS has an external temperature sensor that can be remote mounted with the battery ensuring the charger has the correct battery temperature.

Pin Function Description

Power Pins

On all three connections below there are two pins for + and -, Each pin is rated for 16 amps so two 14 gauge wires are needed to supply the rated 25 amp current.

Main Power In (+ & -)

This input must have a protection fuse with a maximum value of 25 Amps and is typically connected solar or AC power supply.

Backup Battery (+ & -)

This connection goes to your 12 or 24V AGM backup battery and fused with a maximum value of 25 Amps. When the main power is operating correctly a constant float charge will keep the backup battery top off and ready for use in case of a main power failure. Normally the UPS is preconfigured to either 12V or 24Vdc. If this has been mis-configured, internally there is a selectable switch to choose either voltage.



Reverse voltage connection on the Main Power and Backup Battery terminals without installing the external fuses will permanently damage the Bear UPS

Load Out (+ & -)

As long as the main power exceeds 10.8VDC in a 12 volt system and 21.7VDC in a 24 volt the UPS will provide the power to the load. Once the voltage drops below the trip point, the load will be connected to the backup battery for one hour. After which the UPS will disconnect the backup battery from the load. This is to prevent the battery from being deep discharged and damaged if the Main Power is disconnected for an extended period of time.

UPS Control Lines Pins

The FSC needs to override the actuator control lines once a fault is detected.

Temp

This connection is for 10K thermistor that is to be remote mounted to be near the backup battery. This provides the charger with the actual temperature of the battery so the charge voltage can be properly set. If the thermistor is not installed the UPS will not charge the battery and a fail signal will be sent to the FSC.



Not mounting the temperature sensor near the backup battery may result in excessive charging voltage, damaging the battery

Status

When the main power has failed and the UPS is running off the backup battery this output will be the same voltage as the backup battery otherwise its floating.

RS-485 (D- D+ Gnd)

This communication port is for a remote device to have a direct Modbus RTU connection.

To FSC (+ & -) (Main & BU Sense)

This header is a direct connection to the Bear FSC. It provides the FSC with a redundant power (+ & -), and voltage sense Main and BU connections for the FSC to detect a power fault.

Nominal Module Ratings

Parameter		Min	Max	Unit
DC Supply Voltage	12V AGM Battery	10	20	V
	24V AGM Battery	20	35	
Operating and Storage Temperature		-40	50	°C
Quiescent Current	12V AGM Battery		20	mA
	24V AGM Battery		15	
Charge Current		<0.01	5	A
Current Main Power, Backup Battery, Load Out		-	25	A

UPS Control Lines	Min	Max	Unit
FSC +	0	90	mA

Main Power Trip Voltages		Min	Nominal	Max	Unit
Main Power Trip Low	12V AGM Battery	10.7	10.8	10.9	V
	24V AGM Battery	21.6	21.7	21.9	
Main Power Trip Recovery	12V AGM Battery	11.2	11.3	11.4	V
	24V AGM Battery	22.4	22.6	24.8	

Mechanical

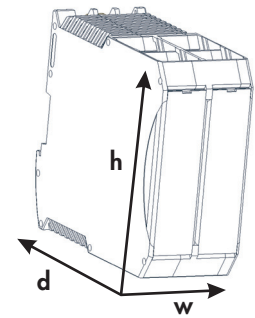

45mm wide x 99mm high x 115mm deep
35mm DIN-rail Connection
Wire Size 12 to 24 AWG and 90°C Minimum

Maintenance and Service

No serviceable parts inside the module or any module within the Bear Fail Safe System.

Terminal Block Placement

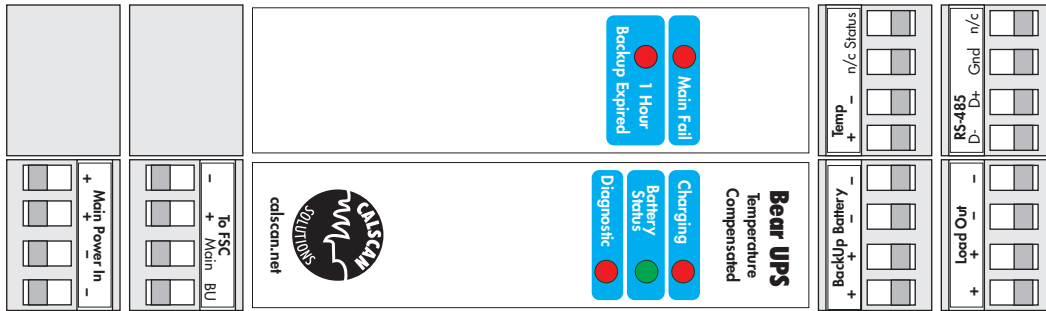

Wiring Example

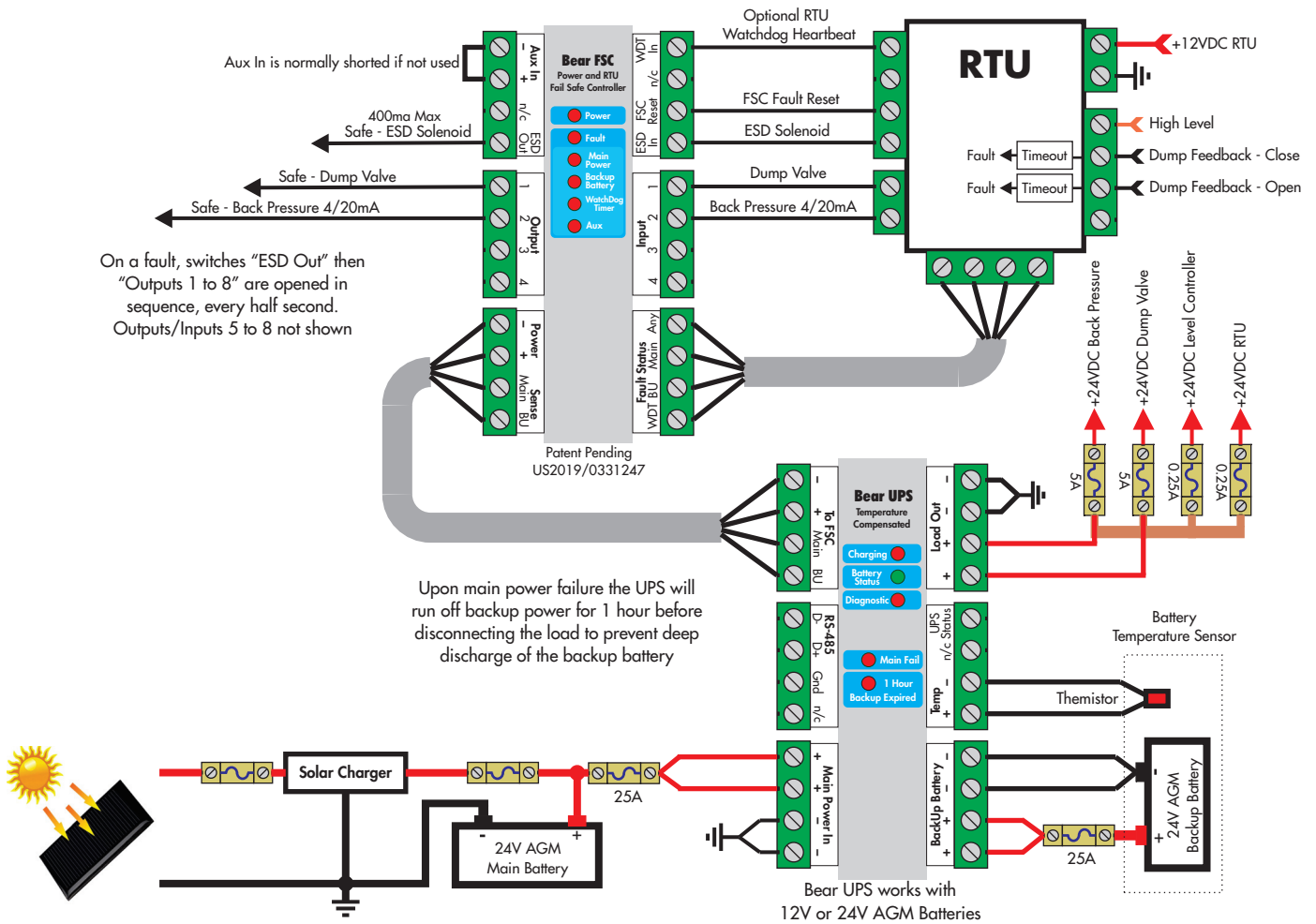

Certification

Class I, Division 2 , Groups C&D T3C
Class I Zone 2 Group IIB T3C
Ambient Temperature: $-40^{\circ}\text{C} \leq T_a \leq 50^{\circ}\text{C}$



Certified to CAN/CSA Std. C22.2 No. 213, 61010-1 and 61010-2-201
Conforms to UL Std. 121201, 61010-1 and 61010-2-201
This module shall be installed and DIN railed inside an approved outdoor rated enclosure

Ordering Information

BUPS –

**OPERATING
VOLTAGE**

-12

= 12 VDC System

-24

= 24 VDC System

Calscan Solutions

4188 93 St NW
Edmonton, Alberta, Canada
T6E 5P5
Ph:780-944-1377
www.calscan.net